



Product information

Ultrasonic

Level measurement in liquids and bulk solids

VEGASON 61

VEGASON 62

VEGASON 63



Document ID: 29023

VEGA

Contents

1	Measuring principle.....	3
2	Type overview.....	4
3	Instrument selection.....	5
4	Selection criteria.....	6
5	Housing overview	7
6	Mounting.....	8
7	Electronics - 4 ... 20 mA/HART - two-wire	9
8	Electronics - 4 ... 20 mA/HART - four-wire	10
9	Electronics - Profibus PA	11
10	Electronics - Foundation Fieldbus	12
11	Operation.....	13
12	Dimensions.....	15

Take note of safety instructions for Ex applications



Please note the Ex specific safety information that you can find at www.vega.com and that comes with each instrument. In hazardous areas you should take note of the appropriate regulations, conformity and type approval certificates of the sensors and power supply units. The sensors must only be operated on intrinsically safe circuits. The permissible electrical values are stated in the certificate.

1 Measuring principle

Measuring principle

VEGASON emits short ultrasonic pulses in the direction of the measured medium. These pulses are reflected by the product surface and received back again by the sensor. The measuring instrument calculates the level from the running time of the sound wave and the entered vessel height. The non-contact measuring principle is unaffected by product properties and allows setup and commissioning even without medium.

Advantages

The compact design enables a simple installation of the sensor. Since the product properties do not influence the level measurement, setup can also be carried out without medium. The inexpensive, non-contact measuring principle allows wear and maintenance free operation.

Input variable

The reference plane for the measurement is the lower edge of the transducer. All statements concerning the measuring range as well as the internal signal processing refer to this.

With all instruments a minimum distance from the lower edge of the flange - the so-called dead band, in which measurement is not possible - must be maintained. You can find the exact value of the dead band in the operating instructions manual of the respective instrument.

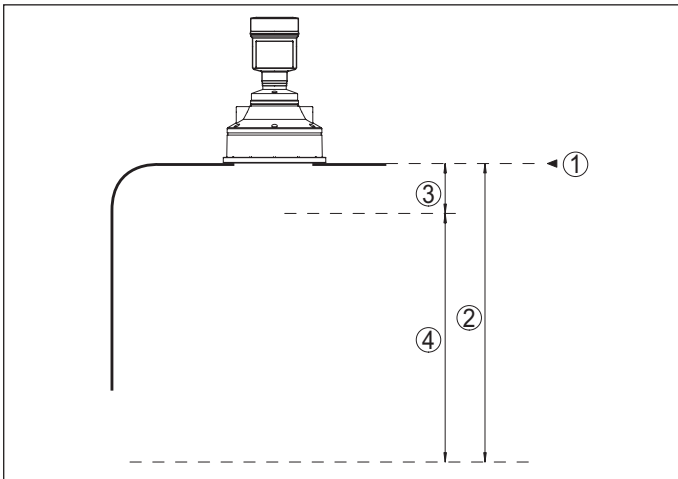

Fig. 1: Data of the input variable with VEGASON 63

- 1 Reference plane
- 2 Max. measuring range
- 3 Dead zone
- 4 Utilisable measuring range

2 Type overview

VEGASON 61



VEGASON 62



VEGASON 63



Applications	Continuous level measurement of liquids or bulk solids in storage vessels or open basins		
Max. measuring range	In liquids: 5 m (16.4 ft) In bulk solids: 2 m (6.562 ft)	In liquids: 8 m (26.25 ft) In bulk solids: 3.5 m (11.48 ft)	In liquids: 15 m (49.21 ft) In bulk solids: 7 m (22.97 ft)
Material transducer	PVDF	PVDF	UP/316 Ti
Material, process fitting	PVDF	PVDF	UP
Process temperature	-40 ... +80 °C (-40 ... +176 °F)	-40 ... +80 °C (-40 ... +176 °F)	-40 ... +80 °C (-40 ... +176 °F)
Process pressure	-0.2 ... +2 bar/-20 ... +200 kPa (-2.9 ... +29 psig)	-0.2 ... +2 bar/-20 ... +200 kPa (-2.9 ... +29 psig)	-0.2 ... +1 bar/-20 ... +100 kPa (-2.9 ... +14.5 psig)
Deviation	±4 mm or < 0.2 %	±4 mm or < 0.2 %	±6 mm or < 0.2 %
Signal output	<ul style="list-style-type: none"> ● 4 ... 20 mA/HART - two-wire ● 4 ... 20 mA/HART - four-wire ● Profibus PA ● Foundation Fieldbus 	<ul style="list-style-type: none"> ● 4 ... 20 mA/HART - two-wire ● 4 ... 20 mA/HART - four-wire ● Profibus PA ● Foundation Fieldbus 	<ul style="list-style-type: none"> ● 4 ... 20 mA/HART - two-wire ● 4 ... 20 mA/HART - four-wire ● Profibus PA ● Foundation Fieldbus
Indication/Adjustment	<ul style="list-style-type: none"> ● PLICSCOM ● PACTware ● VEGADIS 81 ● VEGADIS 82 	<ul style="list-style-type: none"> ● PLICSCOM ● PACTware ● VEGADIS 81 ● VEGADIS 82 	<ul style="list-style-type: none"> ● PLICSCOM ● PACTware ● VEGADIS 81 ● VEGADIS 82
Approvals	<ul style="list-style-type: none"> ● ATEX ● IEC ● Shipbuilding ● FM ● CSA ● EAC (Gost) 	<ul style="list-style-type: none"> ● ATEX ● IEC ● Shipbuilding ● FM ● CSA ● EAC (Gost) 	<ul style="list-style-type: none"> ● Shipbuilding

3 Instrument selection

Application areas

The ultrasonic sensors of the VEGASON series are suitable for non-contact level measurement of liquids and bulk solids in simple applications with stable measurement conditions.

VEGASON 61

VEGASON 61 is an ultrasonic sensor for continuous level measurement of liquids or bulk solids. Typical applications are the measurement of liquids in storage vessels or open basins. The sensor is also suitable for the detection of bulk solids in small vessels or open containers.

VEGASON 62

VEGASON 62 is an ultrasonic sensor for continuous level measurement of liquids or bulk solids. Typical applications are the measurement of liquids in storage vessels or open basins. The sensor is also suitable for the detection of bulk solids in small vessels or silos. Application areas can be found in all industries.

VEGASON 63

VEGASON 63 is an ultrasonic sensor for continuous level measurement of liquids or bulk solids. Typical applications are the measurement of liquids in storage vessels or open basins. The sensor is also suitable for continuous level measurement of bulk solids in small vessels up to average-size vessels.

Applications

Level measurement in vessels

For level measurement in vessels with conical bottom it can be advantageous to mount the sensor in the center of the vessel, as measurement is then possible down to the lowest point of the vessel bottom.

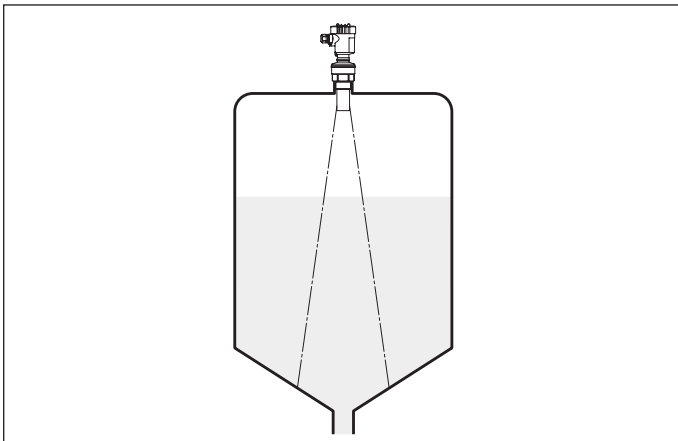

Fig. 5: Level measurement in vessels with conical bottom

Level measurement in a standpipe

When used in a standpipe (surge or bypass tube), the influence of vessel installations, foam generation and turbulence is excluded. Standpipes must reach down to the requested min. level because measurement is only possible within the tube.

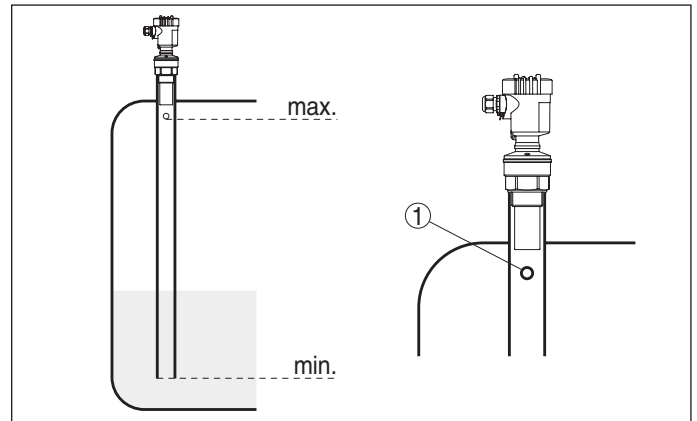

Fig. 6: Standpipe in the tank

1 Vent hole: ϕ 5 ... 10 mm (0.197 ... 0.394 in)

Level measurement in basins

To reduce the min. distance to the medium, you can also mount the VEGASON with a beam deflector. By doing this, it is possible to fill the vessel nearly to maximum. Such an arrangement is suitable primarily for open vessels such as e.g. overflow basins.

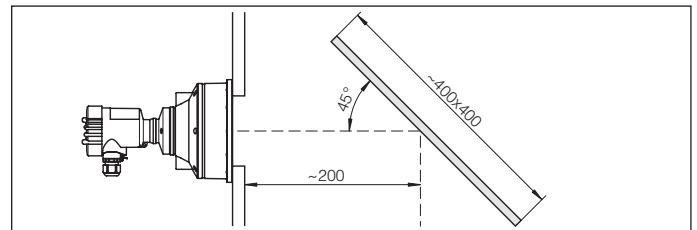





Fig. 7: VEGASON 63 with beam deflector



4 Selection criteria

		VEGASON 61	VEGASON 62	VEGASON 63
Vessel	Small vessels	●	●	●
	Average-size vessels	–	●	●
	Open basins	●	●	●
Process	Flow measurement	●	●	–
	Aggressive products	●	●	–
Installation	Threaded fittings	●	●	–
	Flange connections	●	●	●
	Hygienic fittings	●	●	–
	Mounting strap	–	–	●
Transducer	Measurement in a bypass tube or surge pipe	●	●	●
Suitability for industry-specific applications	Offshore	●	●	●
	Shipbuilding	●	●	●
	Water, waste water	●	●	●

5 Housing overview

Plastic PBT		
Protection rating	IP 66/IP 67	IP 66/IP 67
Version	Single chamber	Double chamber
Application area	Industrial environment	Industrial environment

Aluminium		
Protection rating	IP 66/IP 67, IP 66/IP 68 (1 bar)	IP 66/IP 67, IP 66/IP 68 (1 bar)
Version	Single chamber	Double chamber
Application area	Industrial environment with increased mechanical stress	Industrial environment with increased mechanical stress

Stainless steel 316L			
Protection rating	IP 66/IP 67	IP 66/IP 67, IP 66/IP 68 (1 bar)	IP 66/IP 67, IP 66/IP 68 (1 bar)
Version	Single chamber, electropolished	Single chamber, precision casting	Double chamber, precision casting
Application area	Aggressive environment, food processing, pharmaceutical	Aggressive environment, extreme mechanical stress	Aggressive environment, extreme mechanical stress

6 Mounting

Mounting examples

The following illustrations show mounting examples and measurement setups.

Waste water tank

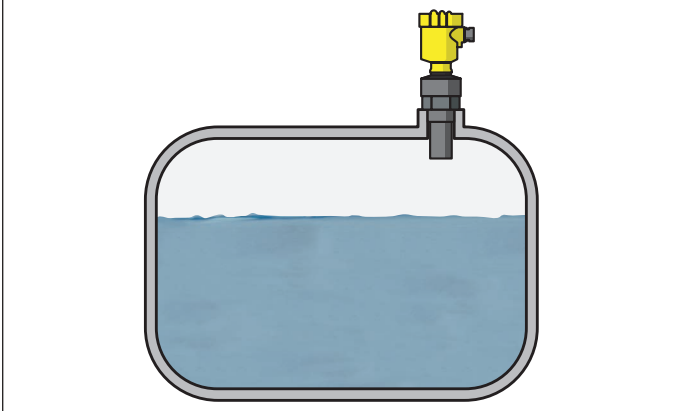

Fig. 15: Level measurement in the waste water tank with VEGASON 61

Due to the solid components and the varying density of the tank contents, non-contact level measurement with ultrasonics is the most suitable method here. The PVDF-encapsulated transducer of VEGASON 61 is resistant against aggressive gases in the tank and requires only a G1½ A mounting boss as process fitting.

Pump shaft

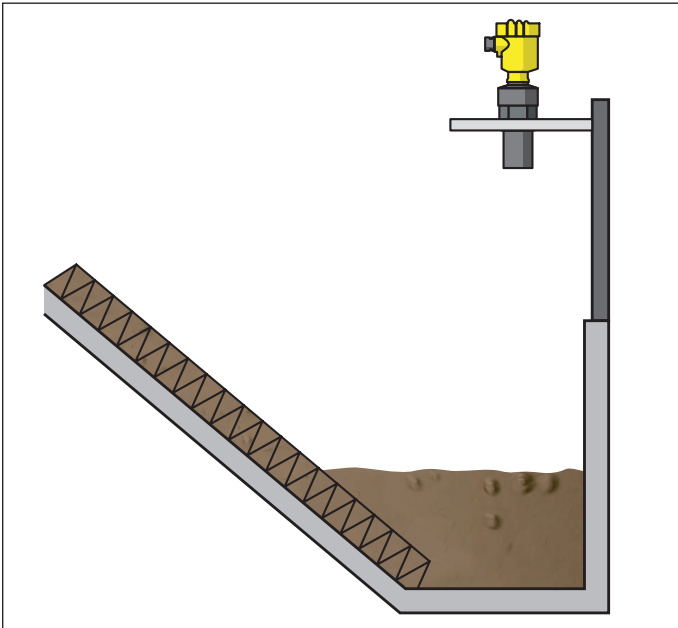

Fig. 16: Level measurement in a pump shaft with VEGASON 62

For simple applications in pump shafts, the contactless ultrasonic sensor VEGASON 62 is used. Independent of the waste water consistency it measures the level without maintenance.

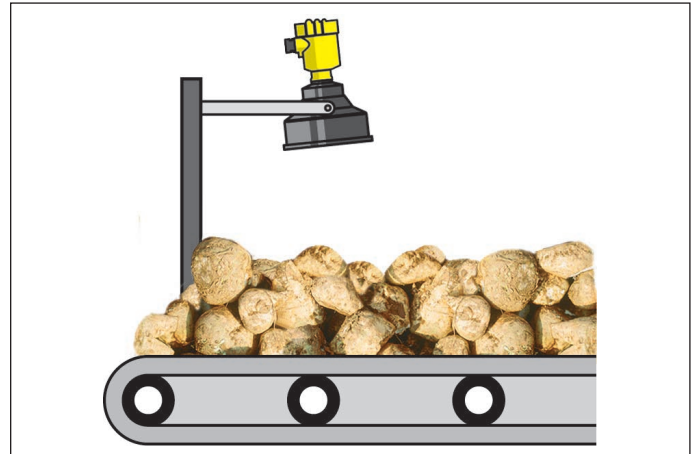

Fig. 17: Profile measurement on a conveyor belt with VEGASON 63

The contactlessly measuring ultrasonic sensor VEGASON 63 is an economical solution for profile monitoring, for example of sugar beets. The ultrasonic waves are reflected by the medium, the integrated electronics determines the loading height of the conveyor belt. By means of the mounting strap, the VEGASON 63 can be optimally oriented to the medium.

7 Electronics - 4 ... 20 mA/HART - two-wire

Configuration of the electronics

The plug-in electronics is mounted in the electronics compartment of the instrument and can be exchanged by the user when servicing is required. The electronics is completely encapsulated to protect against vibration and moisture.

The terminals for voltage supply as well as the contact pins with I²C interface for parameter adjustment are located on the upper side of the electronics. In the double-chamber housing, the terminals are located in the separate terminal compartment.

Voltage supply

Depending on the version, the supply voltage and the current signal are carried on the same two-wire connection cable.

The VEGA power supply units VEGATRENN 141/142, VEGASTAB 690 as well as VEGAMET signal conditioning instruments are suitable for power supply. When one of these instruments is used, a reliable separation of the supply circuits from the mains circuits according to DIN VDE 0106 part 101 is ensured for the sensor.

- Operating voltage
 - 14 ... 36 V DC
- Permissible residual ripple
 - $U_{pp} < 1 \text{ V}$ ($< 100 \text{ Hz}$)
 - $U_{pp} < 10 \text{ mV}$ (100 ... 10 kHz)

Connection cable

The instrument is connected with standard two-wire cable without screen. If electromagnetic interference is expected which is above the test values of EN 61326-1 for industrial areas, screened cable should be used.

We generally recommend the use of screened cable for HART multidrop mode.

Cable screening and grounding

If screened cable is required, we recommend connecting the cable screen on both ends to ground potential. In the sensor, the screen should be connected directly to the internal ground terminal. The ground terminal on the outside of the housing must be connected to the ground potential (with low impedance).

Connection single chamber housing

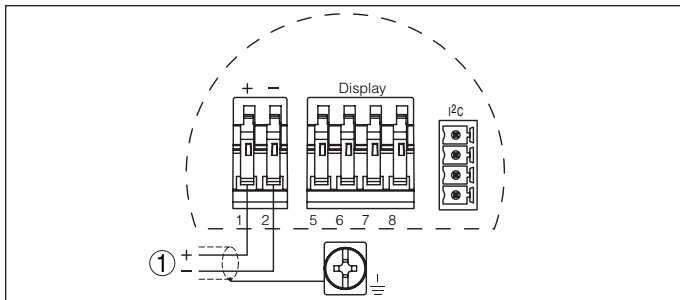

Fig. 18: Wiring plan, single chamber housing

1 Voltage supply, signal output

Connection, double chamber housing

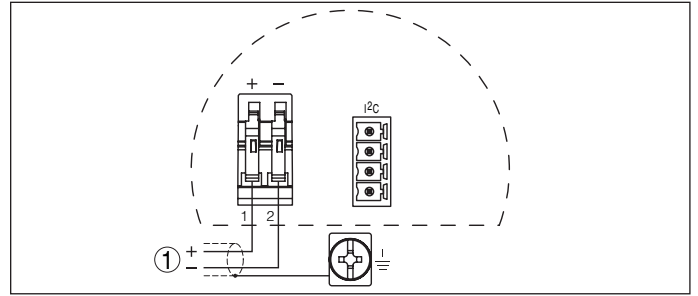

Fig. 19: Wiring plan, double chamber housing

1 Voltage supply, signal output

8 Electronics - 4 ... 20 mA/HART - four-wire

Configuration of the electronics

The plug-in electronics is mounted in the electronics compartment of the instrument and can be exchanged by the user when servicing is required. The electronics is completely encapsulated to protect against vibration and moisture.

The terminals for voltage supply as well as the contact pins with I²C interface for parameter adjustment are located on the upper side of the electronics. In the double-chamber housing, the terminals are located in the separate terminal compartment.

Voltage supply

If a reliable separation is required, the power supply and the current output are transmitted over separate two-wire connection cables.

- Operating voltage
 - 20 ... 72 V DC, 20 ... 253 V AC, 50/60 Hz

Connection cable

The 4 ... 20 mA current output is connected with standard two-wire cable without screen. If electromagnetic interference is expected which is above the test values of EN 61326 for industrial areas, screened cable should be used.

For power supply, an approved installation cable with PE conductor is required.

Cable screening and grounding

If screened cable is required, we recommend connecting the cable screen on both ends to ground potential. In the sensor, the screen should be connected directly to the internal ground terminal. The ground terminal on the outside of the housing must be connected to the ground potential (with low impedance).

Connection, double chamber housing

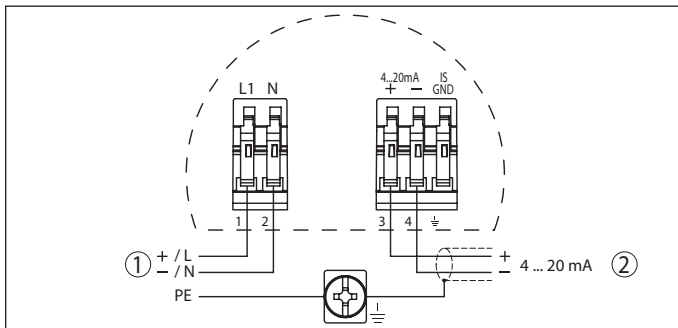

Fig. 20: Terminal compartment, double chamber housing

- 1 Spring-loaded terminals for voltage supply
- 2 4 ... 20 mA signal output active

Terminal	Function	Polarity
1	Voltage supply	+ / L
2	Voltage supply	- / N
3	4 ... 20 mA output (active)	+
4	4 ... 20 mA output (active)	+
	Functional ground with installation according to CSA	

9 Electronics - Profibus PA

Configuration of the electronics

The plug-in electronics is mounted in the electronics compartment of the instrument and can be exchanged by the user when servicing is required. The electronics is completely encapsulated to protect against vibration and moisture.

The terminals for voltage supply as well as the plug with I²C interface for parameter adjustment are located on the upper side of the electronics. In the double-chamber housing, these connection elements are located in the separate terminal compartment.

Voltage supply

The voltage supply is provided by a Profibus DP /PA segment coupler.

Specifications of the voltage supply:

- Operating voltage
 - 9 ... 32 V DC
- Max. number of sensors per DP/PA segment coupler
 - 32

Connection cable

Connection is carried out with screened cable according to Profibus specification.

Make sure that the entire installation is carried out according to the Profibus specification. In particular, make sure that the bus is terminated with suitable terminating resistors.

Cable screening and grounding

In systems with potential equalisation, connect the cable screen directly to ground potential at the power supply unit, in the connection box and at the sensor. The screen in the sensor must be connected directly to the internal ground terminal. The ground terminal outside on the housing must be connected to the potential equalisation (low impedance).

In systems without potential equalisation, connect the cable screen directly to ground potential on the power supply unit and the sensor. In the connection box or T-distributor, the screen of the short stub to the sensor may not be connected to ground potential or to another cable screen.

Connection single chamber housing

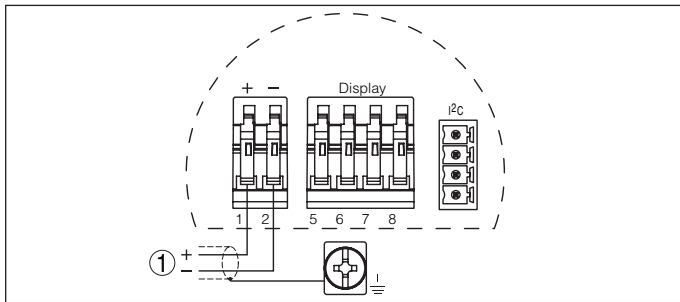

Fig. 21: Wiring plan, single chamber housing

1 Voltage supply, signal output

Connection, double chamber housing

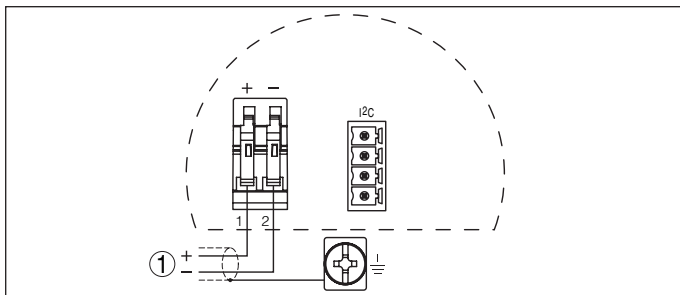

Fig. 22: Wiring plan, double chamber housing

1 Voltage supply, signal output

10 Electronics - Foundation Fieldbus

Configuration of the electronics

The plug-in electronics is mounted in the electronics compartment of the instrument and can be exchanged by the user when servicing is required. The electronics is completely encapsulated to protect against vibration and moisture.

The terminals for voltage supply as well as the plug with I²C interface for parameter adjustment are located on the upper side of the electronics. In the double-chamber housing, these connection elements are located in the separate terminal compartment.

Voltage supply

Power supply via the H1 Fieldbus cable.

Specifications of the voltage supply:

- Operating voltage
 - 9 ... 32 V DC
- max. number of sensors
 - 32

Connection cable

Connection is carried out with screened cable according to Fieldbus specification.

Make sure that the entire installation is carried out according to the Fieldbus specification. In particular, make sure that the bus is terminated with suitable terminating resistors.

Cable screening and grounding

In systems with potential equalisation, connect the cable screen directly to ground potential at the power supply unit, in the connection box and at the sensor. The screen in the sensor must be connected directly to the internal ground terminal. The ground terminal outside on the housing must be connected to the potential equalisation (low impedance).

In systems without potential equalisation, connect the cable screen directly to ground potential on the power supply unit and the sensor. In the connection box or T-distributor, the screen of the short stub to the sensor may not be connected to ground potential or to another cable screen.

Connection single chamber housing

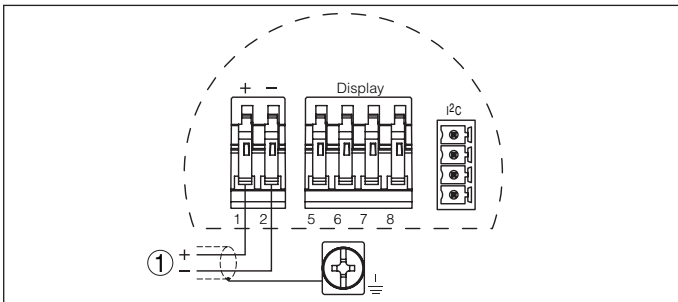

Fig. 23: Wiring plan, single chamber housing

1 Voltage supply, signal output

Connection, double chamber housing

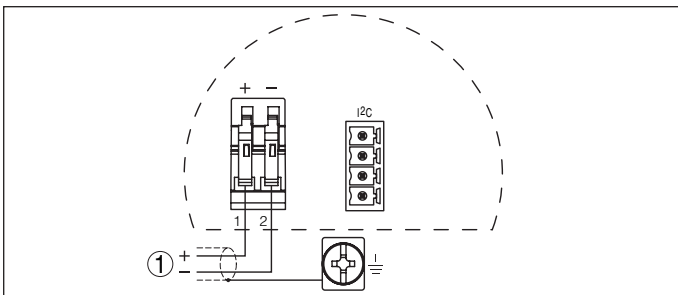

Fig. 24: Wiring plan, double chamber housing

1 Voltage supply, signal output

11 Operation

11.1 Adjustment on the measurement loop

Via the display and adjustment module through keys

The plug-in display and adjustment module is used for measured value indication, adjustment and diagnosis. It is equipped with an illuminated full dot matrix as well as four keys for adjustment.



Fig. 25: Display and adjustment module with single chamber housing

Via the display and adjustment module through magnetic pen

With the Bluetooth version of the display and adjustment module, the sensor can also be adjusted with the magnetic pen. This is done right through the closed lid (with inspection window) of the sensor housing.



Fig. 26: Display and adjustment module - with adjustment via magnetic pen

Via a PC with PACTware/DTM

The interface converter VEGACONNECT is required for connection of the PC. The converter is placed on the sensor instead of the display and adjustment module and connected to the USB interface of the PC.



Fig. 27: Connection of the PC via VEGACONNECT and USB

- 1 VEGACONNECT
- 2 Sensor
- 3 USB cable to the PC
- 4 PC with PACTware/DTM

PACTware is an adjustment software for configuration, parameter adjustment, documentation and diagnosis of field devices. The corresponding device drivers are called DTMs.

11.2 Operation in the measurement loop environment - wireless via Bluetooth

Via a smartphone/tablet

The display and adjustment module with integrated Bluetooth functionality allows wireless connection to smartphones/tablets with iOS or Android operating system. The adjustment is carried out via the VEGA Tools app from the Apple App Store or Google Play Store.

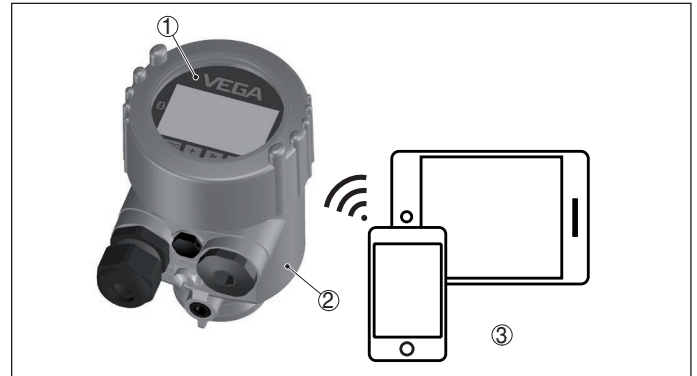

Fig. 28: Wireless connection to smartphones/tables

- 1 Display and adjustment module
- 2 Sensor
- 3 Smartphone/Tablet

Via a PC with PACTware/DTM

The wireless connection from the PC to the sensor is carried out via the Bluetooth USB adapter and a display and adjustment module with integrated Bluetooth function. The adjustment is carried out via the PC with PACTware/DTM.



Fig. 29: Connection of the PC via Bluetooth adapter

- 1 Display and adjustment module
- 2 Sensor
- 3 Bluetooth USB adapter
- 4 PC with PACTware/DTM

11.3 Adjustment carried out at position remote from the measuring point - wired

Via external display and adjustment units

For this, the external display and adjustment units VEGADIS 81 and 82 are available. The adjustment is carried out via the keys of the built-in display and adjustment module.

The VEGADIS 81 is mounted at a distance of 50 m from the sensor and directly to the sensor electronics. VEGADIS 82 is looped directly into the signal cable at any point.

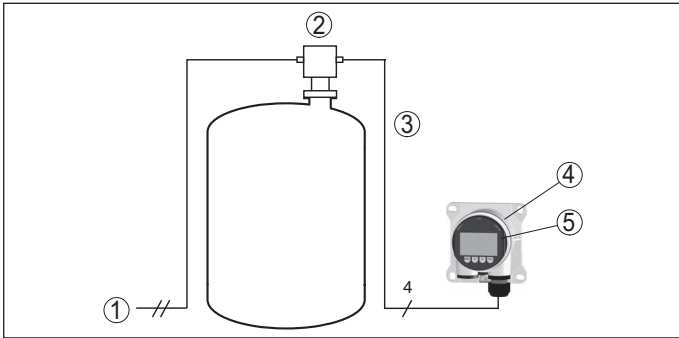

Fig. 30: Connection of VEGADIS 81 to the sensor

- 1 Voltage supply/Signal output sensor
- 2 Sensor
- 3 Connection cable sensor - external display and adjustment unit
- 4 External display and adjustment unit
- 5 Display and adjustment module

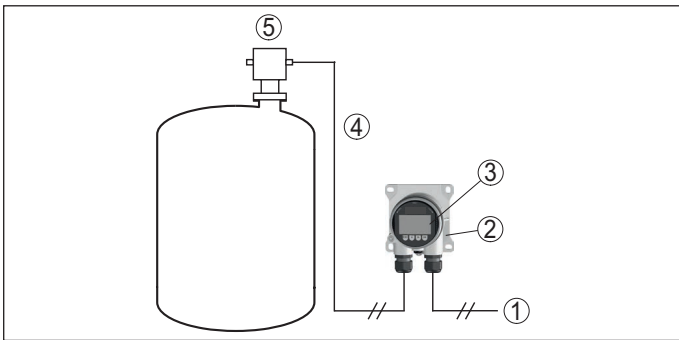

Fig. 31: Connection of VEGADIS 82 to the sensor

- 1 Voltage supply/Signal output sensor
- 2 External display and adjustment unit
- 3 Display and adjustment module
- 4 ... 20 mA/HART signal cable
- 5 Sensor

Via a PC with PACTware/DTM

The sensor adjustment is carried out via a PC with PACTware/DTM.

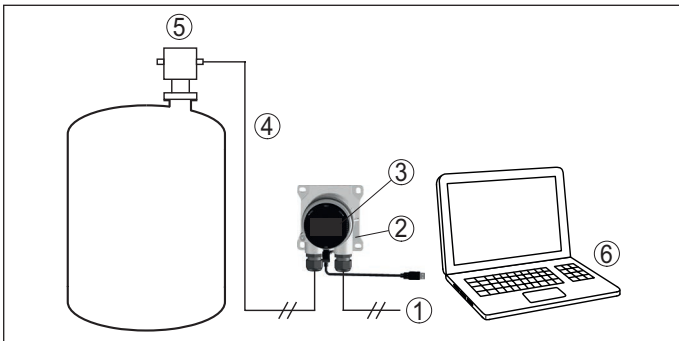

Fig. 32: Connection of VEGADIS 82 to the sensor, adjustment via PC with PACTware

- 1 Voltage supply/Signal output sensor
- 2 External display and adjustment unit
- 3 VEGACONNECT
- 4 ... 20 mA/HART signal cable
- 5 Sensor
- 6 PC with PACTware/DTM

11.4 Adjustment carried out at position remote from the measuring point - wireless through mobile network

As an option, the radio module PLICSMOBILE can be mounted into a plics® sensor with double chamber housing. It is used for transmission of measured values and for remote parameter adjustment of the sensor.

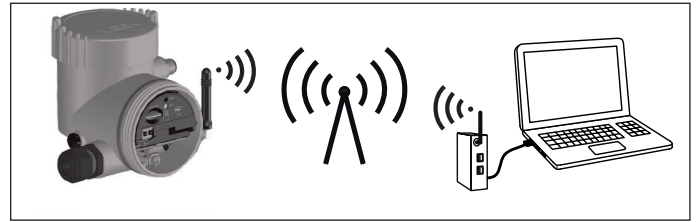

Fig. 33: Transmission of measured values and remote parameter adjustment of the sensor via mobile phone network.

11.5 Alternative adjustment programs

DD adjustment programs

Device descriptions as Enhanced Device Description (EDD) are available for DD adjustment programs such as, for example, AMS™ and PDM.

The files can be downloaded at www.vega.com/downloads under "Software".

Field Communicator 375, 475

Device descriptions for the instrument are available as EDD for parameter adjustment with the Field Communicator 375 or 475.

For the integration of the EDD in the Field Communicator 375 or 475, the software "Easy Upgrade Utility" is required which is available from the manufacturer. This software is updated via the Internet and new EDDs are automatically taken over into the device catalogue of this software after they are released by the manufacturer. They can then be transferred to a Field Communicator.

12 Dimensions

Plastic housing

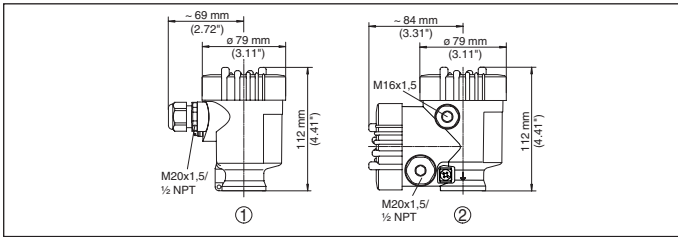

- 1 Single chamber housing
- 2 Double chamber housing

Aluminium housing

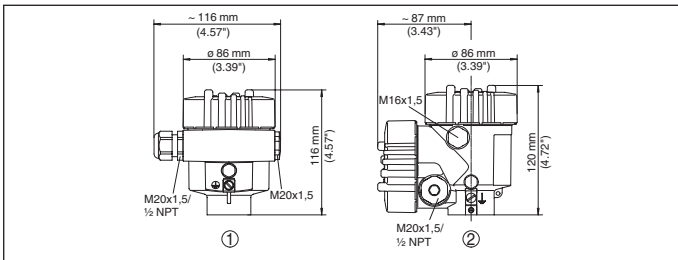

- 1 Single chamber housing
- 2 Double chamber housing

Stainless steel housing

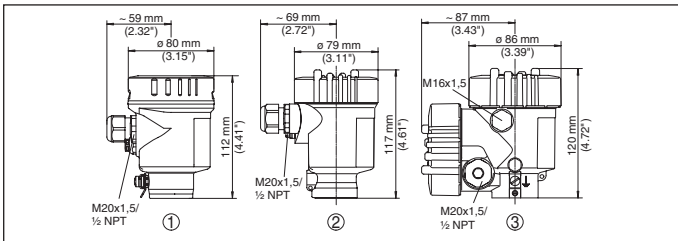

- 1 Single chamber housing, electropolished
- 2 Single chamber housing, precision casting
- 3 Double chamber housing, precision casting

VEGASON 61

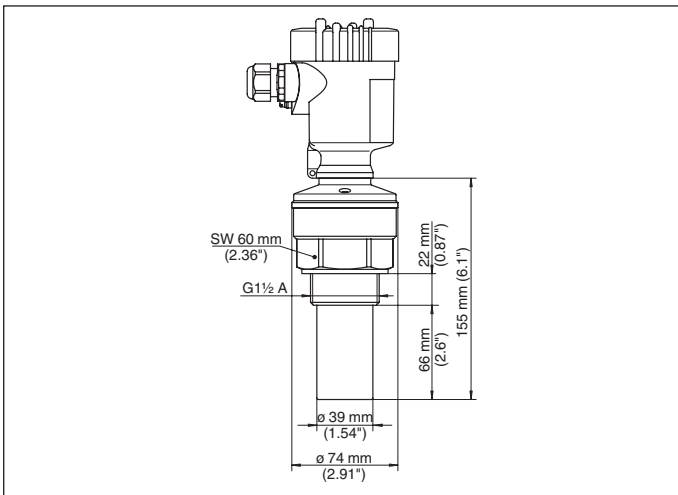

VEGASON 62

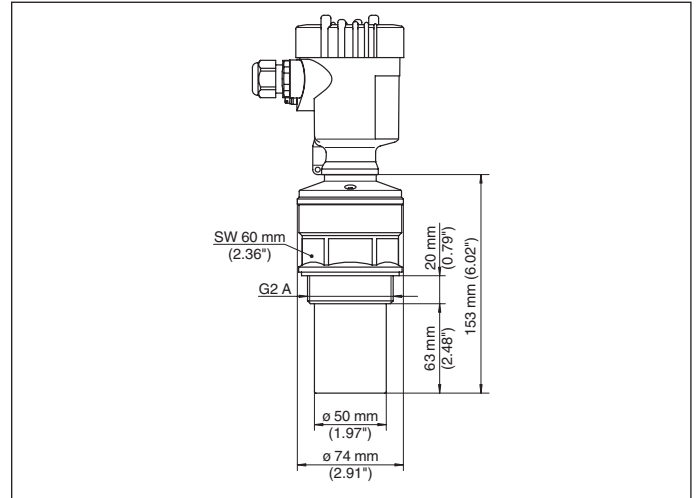

VEGASON 63

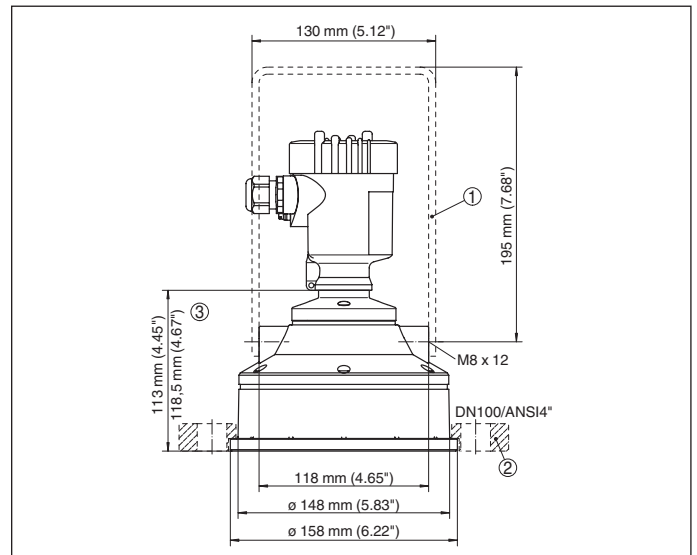

- 1 Mounting strap
- 2 Compression flange DN 80

The listed drawings represent only an excerpt of the available process fittings. You can find more drawings at www.vega.com/downloads under "Drawings".



All statements concerning scope of delivery, application, practical use and operating conditions of the sensors and processing systems correspond to the information available at the time of printing.
Subject to change without prior notice

© VEGA Grieshaber KG, Schiltach/Germany 2016

VEGA Grieshaber KG
Am Hohenstein 113
77761 Schiltach
Germany

Phone +49 7836 50-0
Fax +49 7836 50-201
E-mail: info.de@vega.com
www.vega.com

VEGA